

# CHEMICAL INJECTION THROTTLE VALVES (CTVS)

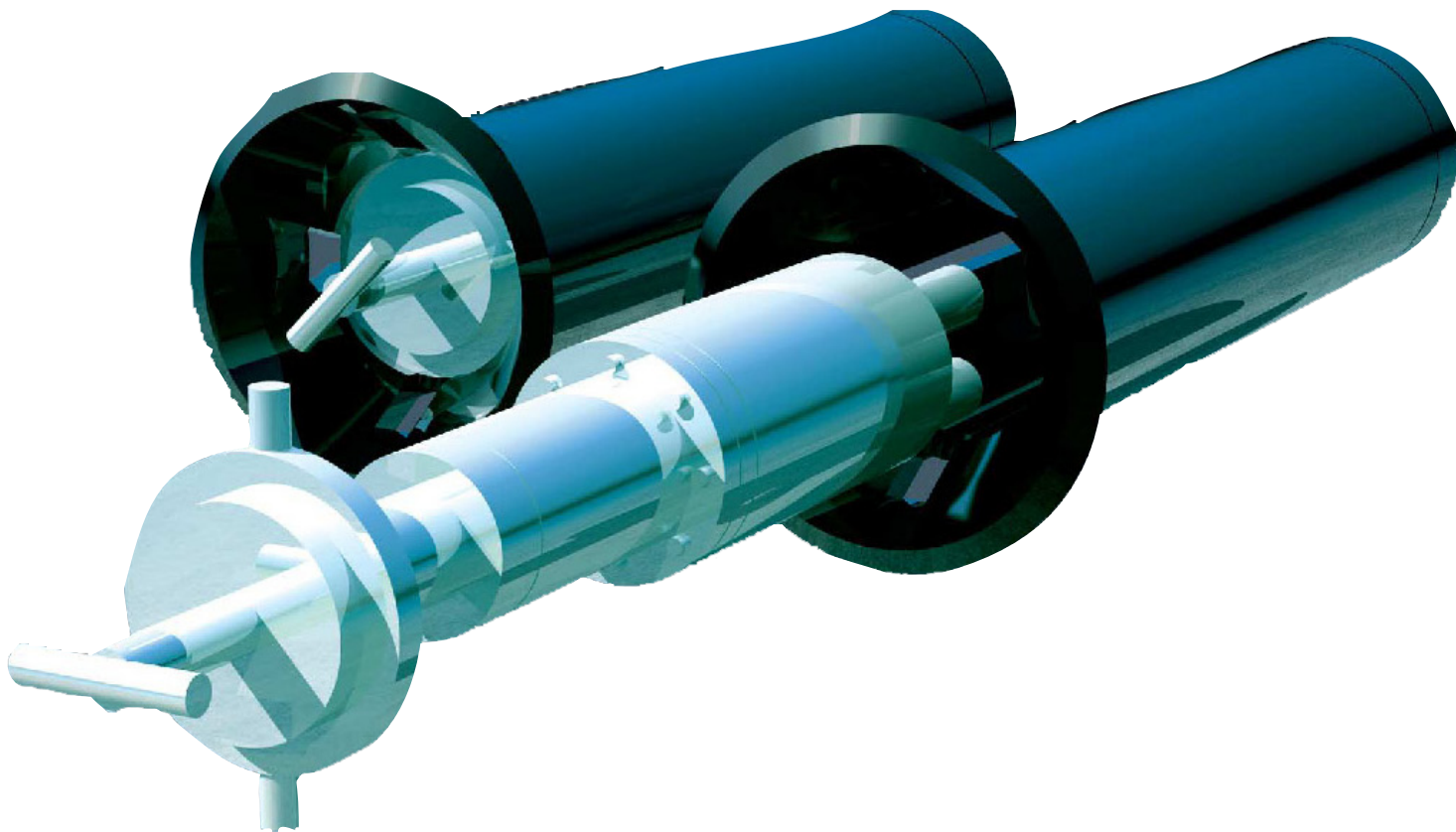

Oceaneering Rotator designs and manufactures Chemical Injection Throttle Valves (CTVs) for subsea applications worldwide. Since 1993 Rotator has delivered in excess of 300 valves of which over 100 units are electric remote operated. Rotator CTV Valves pass stringent quality testing procedures and exhibit performance and reliability results that meet or exceed or customers' expectations.

CTVs are used for precise injection of scale, corrosion, or wax inhibitors in oil and gas production systems and are retrievable by a standard work class ROV. The VisCom<sup>®</sup> CTV, a newly designed valve, has a built in viscosity compensated flow measurement loop and is retrievable with a three (3) function manipulator and a torque tool.



# CHEMICAL INJECTION THROTTLE VALVES (CTVS)

## Features:

- A flow ratio up to 100:1 will ensure adequate injection capacity with differential pressure typically between 60 and 200 bar
- Large internal passages. Can handle fluid contamination up to SAE AS4059 Class 12B-F
- Integrated self cleaning feature ensures minimum risk of clogging
- Tolerant to reverse pressure conditions and pressure transients
- Integrated flow measurement
- Pressure sensor for continuous monitoring of pressure
- Integrated electrical controller unit for remote adjustment and monitoring of flowrate
- Simple 4-wire communication and power interface
- Low power consumption during actuation
- No movable parts except during actuation
- Mechanical end stop function

## Performance Benefits:

- Simple and rugged design
- Precise adjustable throttle mechanism
- No sudden pressure drop. Differential pressure (DP) created over a long thin "pipe" and not over a sharp edge preventing erosion and cavitation
- Integrated flow meter accurately measures actual chemical injection flow rate - high flow measurement turndown ratio
- Absolute pressure transducers measure pressure drop across fixed laminar restrictor
- Contamination tolerant design with large flow openings
- Built in mechanical scraper / self cleaning system
- Chemical Throttle Valve can be designed as a separate diver/ROV retrievable unit or for mounting inside a control pod
- Field proven

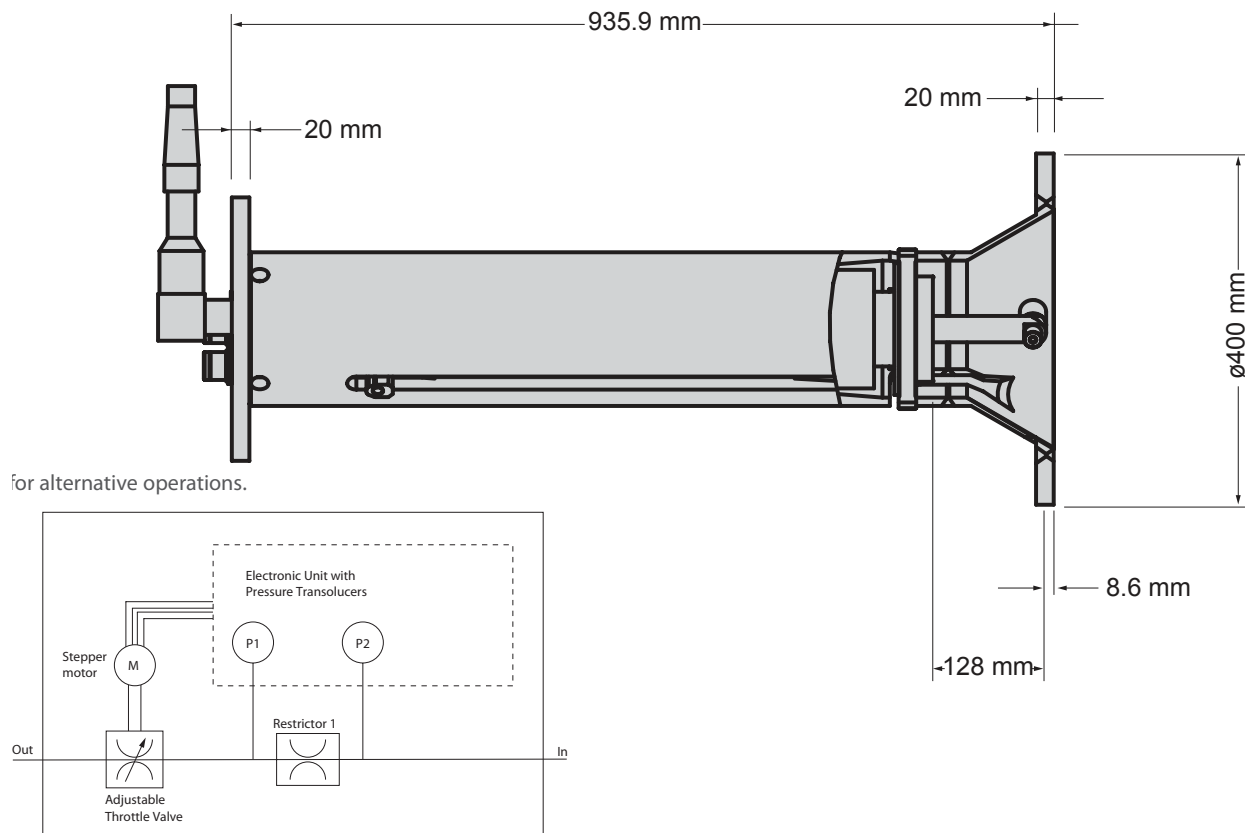

Rotator standard CTV schematic

