

ELECTRICAL ISOLATION JOINT (EIJ)

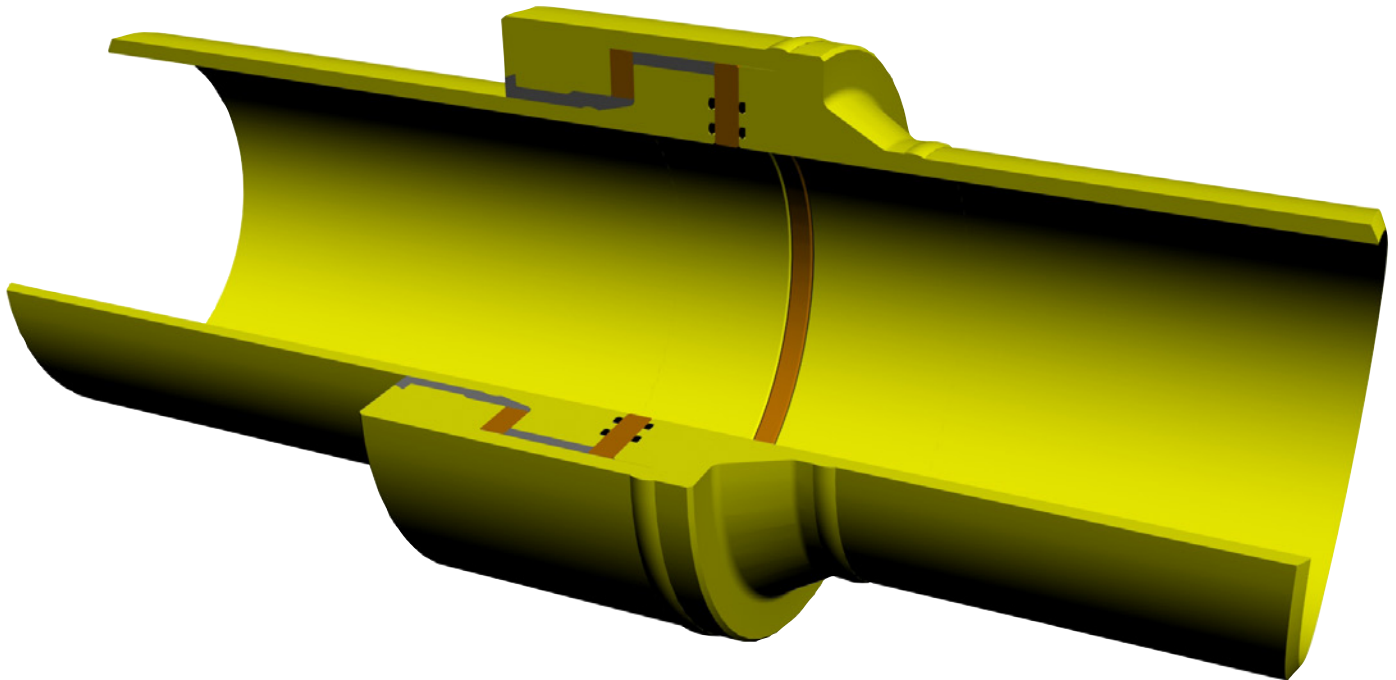

Oceaneering's Electrical Isolation Joint (EIJ) isolates the cathodic protection current in a pipeline from other sources that can act as current drains. These current draining sources such as power plants, equipment, steel reinforced concrete and other grounded structures must be isolated in order to achieve and maintain adequate, reliable and economical corrosion control. The EIJ is frequently used offshore to isolate the riser from the jacket structure where a potential difference exists between the two cathodic

protection systems. It may also be used to minimize galvanic action between pipelines of dissimilar metals.

The "Monoblock" style design of the EIJ is prefabricated, electrically tested and pressure tested at the factory. This type of design provides superior pressure containment and mechanical strength. Dual elastomeric seals are used to assure high quality long-term pressure integrity and mechanically, the EIJ is designed to be as strong as the pipeline.



ELECTRICAL ISOLATION JOINT (EIJ) SPECIFICATIONS

Design Parameters:

- Nominal Pipe Size (NPS): any API Specification 5L pipe, wall thickness and grade
- Service: Standard (i.e. crude oil, natural gas, hydrocarbons, water or chemical injection, etc.) and Sour (i.e. hydrogen sulfide, carbon dioxide, etc.)
- Design Pressure Rating: up to ASME Class 2500
- Hydrostatic Test Pressure (min): 1.5 times Design Pressure Rating rounded up to nearest 25 psig
- Hydrostatic Test Duration (min): 1-hr
- Design Temperature Range: 25°F (-4°C) to 200°F (93°C)
- Design Life: 20-yrs
- Electrical Resistance (min): 40 MΩ with 1000 VDC applied potential
- Leakage Current (max): 5 mA with 2500 VAC (60 Hz) applied potential
- Dielectric Strength (min breakdown voltage): 20 kV

Material Specifications:

- End, Inner and Closure Flange: ASTM A105N or ASTM A694 Gr. F52 forging (or otherwise customer specified)
- Pipe Pups: API 5L, wall thickness and grade to match pipeline (otherwise customer supplied)
- Insulating Rings: Glass-filled epoxy laminate, Micarta NEMA grade G10
- Elastomeric Seals: Viton O-Rings (other seal types and materials to meet customer specifications)
- Silicon Elastomer: Dow Corning Sylgard® 160 (injected)
- External Coating: Carboline 890 Epoxy Paint System, Safety Yellow Color

Applicable Design Codes, Standards & Specifications (latest editions):

- OIE/PCRS Group Electrical Insulating Joint Drawings, Bill of Materials (Controlled Copies) and Vendor Supplied Material Test Reports
- OIE ISO 9001:2000 Quality Assurance - Quality Control Procedures & PCRS Operating Procedures
- ASME Boiler Pressure Vessel Code, Section V Nondestructive Examination
- ASME Boiler Pressure Vessel Code, Section VIII, Division 1 and 2
- ASME Boiler Pressure Vessel Code, Section IX Welding and Brazing Qualifications
- ASME B31.4, Pipeline Transportation Systems for Liquid Hydrocarbons and Other Liquids
- ASME B31.8, Gas Transmission and Distribution Systems
- API SPEC 5L, Specification for Line Pipe
- NACE RP0286, The Electrical Isolation of Cathodically Protected Pipelines
- NACE MR0175, Metals for Sulfide Stress Cracking and Stress Corrosion Cracking Resistance in Sour Oilfield Environments

Certifications:

- ISO 9001:2008 - World Certification Services Ltd. - Accredited by UKAS Quality Management
- EN 10204 Section 3.1.B (DIN 50049), Inspection Documents for the Delivery of Metallic Products

