

DIVERLESS CONNECTION & REPAIR SYSTEMS

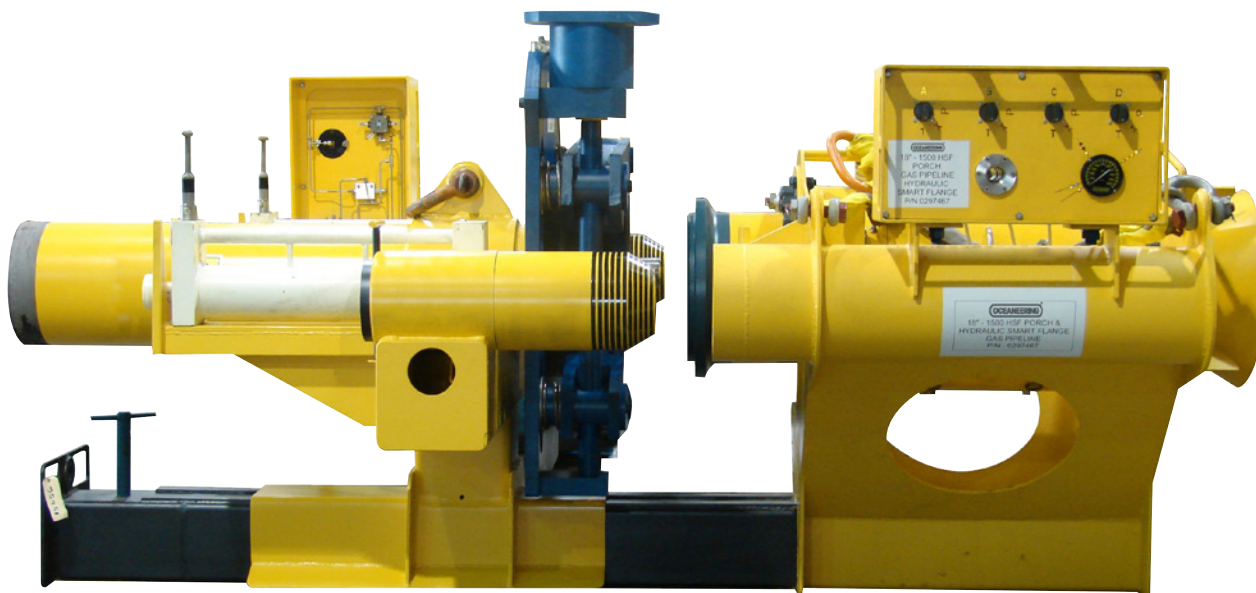

A GRAYLOC® Remote Clamp Connector is the basis for the Diverless Connection & Repair System. The clamp connector uses a single drive screw with a standard API torque bucket for make up by an industry standard, Remotely Operated Vehicle (ROV) torque tool.

System Features:

- Simple, reliable trunnion and screw mechanism
- ROV friendly design
- Self-supporting base plate
- Grayloc® metal to metal seal
- Metal seal ring is ROV removable and re-installable
- Quick connect / disconnect capability
- Horizontal or Vertical designs



DIVERLESS CONNECTION & REPAIR SYSTEMS SPECIFICATIONS

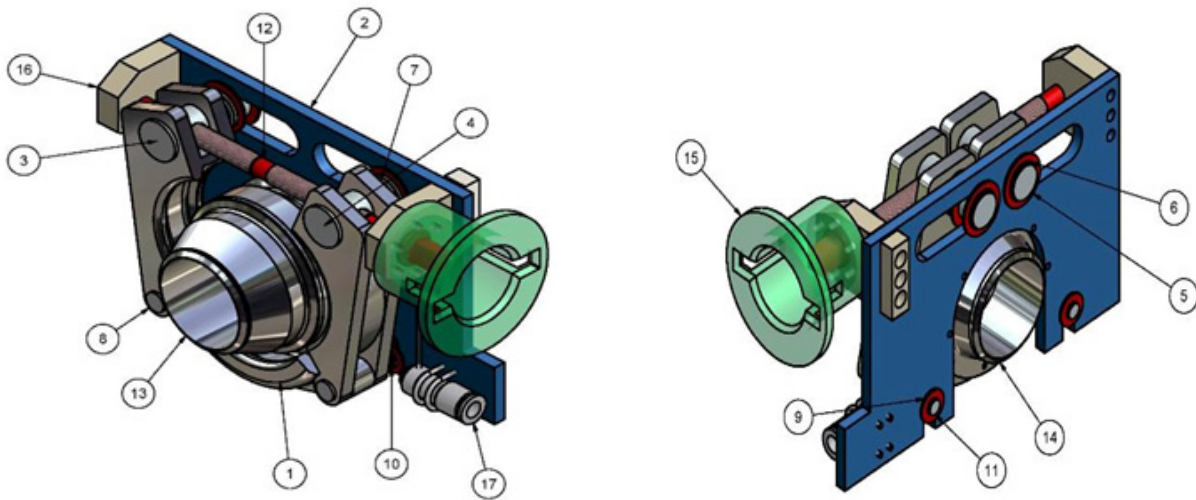

Item	Qty.	Description	Material Grade	Coating	NDE
1	1	Clamp Body Assembly	SA487-4B		RT, MPI
2	1	Support Plate	Carbon Steel		-----
3	1	Trunnion, Right Hand	ASTM A193 Grade B7	Xylan 1070	UT, MPI
4	1	Trunnion, Left Hand			
5	4	Trunnion Washer	Carbon Steel		-----
6	2	Trunnion Retainer			
7	2	Trunnion Spring	Stainless Steel	-----	-----
8	2	Hinge Pin	ASTM A193 Grade B7	Xylan 1070	UT, MPI
9	4	Hinge Pin Washer	Carbon Steel		
10	2	Hinge Pin Spring	Stainless Steel	-----	-----
11	2	Hinge Pin Retainer	Carbon Steel	Xylan 1070	-----
12	1	Drive Screw	Alloy 718		
13	1	⁽¹⁾ Male Grayloc® Hub	(To match customer's pipe)	Xylan 1070 (External Surfaces Only)	UT, MPI or LPI
14	1	⁽¹⁾ Female Grayloc® Hub			
15	1	API Torque Bucket	Carbon Steel	Xylan 1070	MPI
16	1	Drive Screw Stop Plate			
17	1	Female Hot Stab	Stainless Steel	-----	-----
18	1	Grayloc® Seal Ring (Not Shown)	Alloy 718	PTFE	UT, LPI

Notes: ⁽¹⁾Carbon steel and low alloy steel Grayloc® hubs are provided with corrosion resistant alloy inlay in the seal area.

