

Diverless Connection System - Horizontal

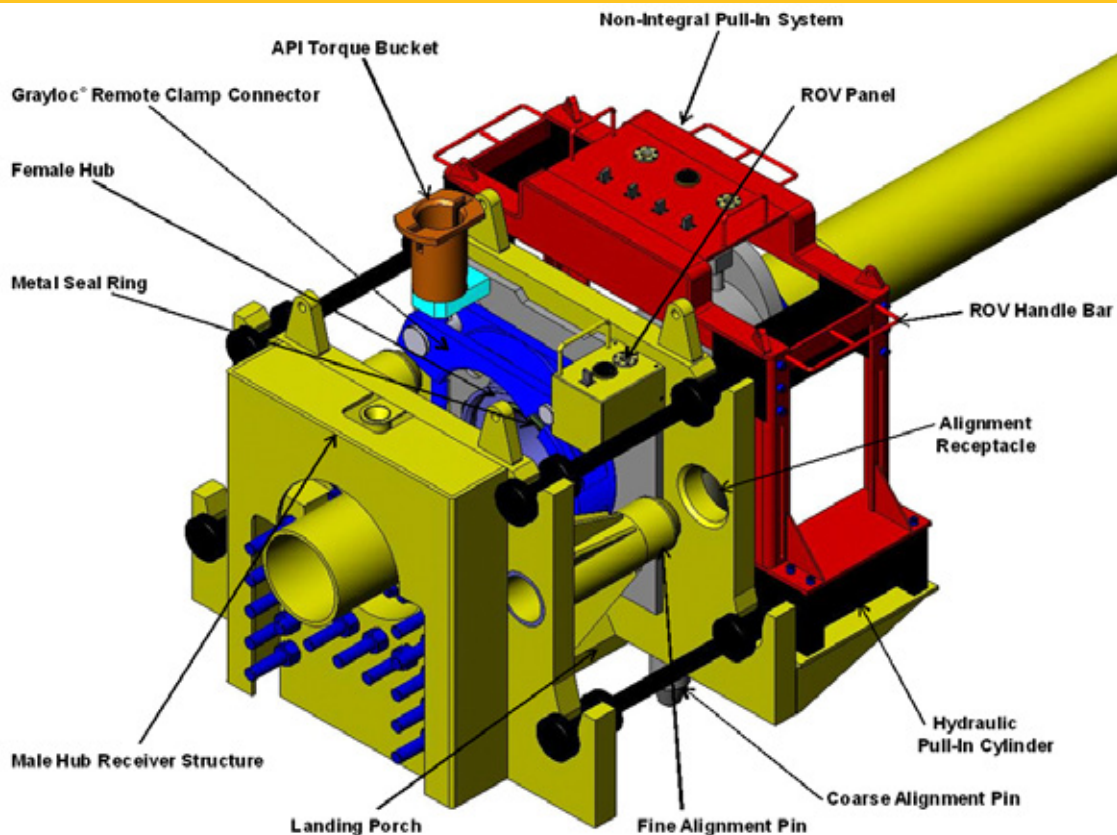

Horizontal Diverless Connection System utilizes the GRAYLOC® Remote Clamp Connector for fast and reliable pipeline and flowline tie-ins in water depths beyond divers' capabilities. The system relies on a ROV operated three segment clamp connector to make the connection between the two hubs (female and male), capturing a patented Grayloc® metal seal ring in between.

The clamp connector utilizes a single drive screw with a standard API Torque Bucket and is made up using an industry standard ROV Torque Tool. The jumper connector with the female hub retains the metal seal ring with a series of retainer blocks. Once the clamp connector is fully made up, an annulus test port is located on the backing plate of the connector allows for the verification of the sealing integrity. A simple, non-integral pull-in system is required for the installation of the horizontal connection system. The system is recovered to the surface after the installation.

Grayloc® Remote Clamp Connector

- Simple, reliable Trunnion & Screw Mechanism
- Single Drive Screw Adaptable for ROV Operations
- Self-Supporting Base Plate for Unitized Design
- Retains Metal-To-Metal Grayloc® Metal Seal Ring, ROV Removable & Installable
- Quick Connect / Disconnect Capability
- Provides with Connection as Strong as the Pipe
- No Running Tool Required
- No Hydraulics Left on the Bottom

Diverless Connection System - Horizontal Specifications

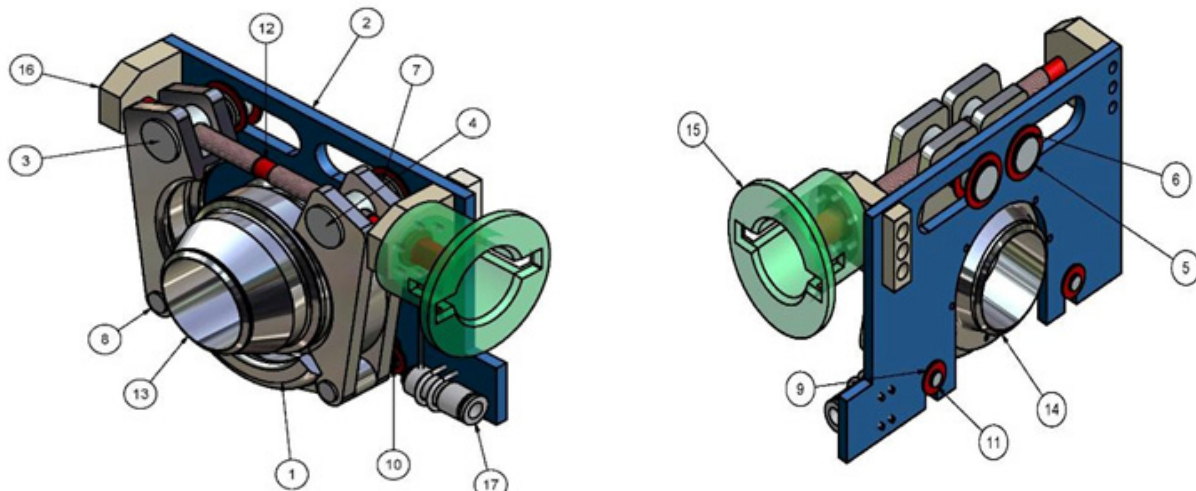

Item	Qty.	Description	Material Grade	Coating	NDE
1	1	Clamp Body Assembly	SA487-4B		RT, MPI
2	1	Support Plate	Carbon Steel		-----
3	1	Trunnion, Right Hand	ASTM A193 Grade B7	Xylan 1070	UT, MPI
4	1	Trunnion, Left Hand			
5	4	Trunnion Washer	Carbon Steel		-----
6	2	Trunnion Retainer			-----
7	2	Trunnion Spring	Stainless Steel	-----	-----
8	2	Hinge Pin	ASTM A193 Grade B7	Xylan 1070	UT, MPI
9	4	Hinge Pin Washer	Carbon Steel		
10	2	Hinge Pin Spring	Stainless Steel	-----	-----
11	2	Hinge Pin Retainer	Carbon Steel	Xylan 1070	-----
12	1	Drive Screw	Alloy 718		
13	1	⁽¹⁾ Male Grayloc® Hub	(To match customer's pipe)	Xylan 1070 (External Surfaces Only)	UT, MPI or LPI
14	1	⁽¹⁾ Female Grayloc® Hub			
15	1	API Torque Bucket	Carbon Steel	Xylan 1070	MPI
16	1	Drive Screw Stop Plate			
17	1	Female Hot Stab	Stainless Steel	-----	-----
18	1	Grayloc® Seal Ring (Not Shown)	Alloy 718	PTFE	UT, LPI

Notes: ⁽¹⁾Carbon steel and low alloy steel Grayloc® hubs are provided with corrosion resistant alloy inlay in the seal area.

