

# SEA MAXX

## SATELLITE ROV SYSTEM

### General System Description

The Sea Maxx ROV is a true deep water Observation and Inspection system. It is designed to operate in tandem, as a Satellite to a larger Work Class ROV. Maxx's small size makes it ideal to inspect those difficult to reach and confined areas that a larger Work Class ROV can't access.

The Sea Maxx system consists of the ROV, a small Launch and Recovery (L/R) cage and a tether management module with 125 meters of tether cable. The system is installed as part of a Work Class ROV package with the small L/R cage mounted to the underside of Work Class ROV L/R cage. The Sea Maxx ROV is controlled via a fiber optic link thru the Work Class ROV main armored umbilical cable. The control CPU, display and joystick controls are mounted along side the Work Class ROV controls and displays allowing for tandem or independent operations.



### Key Features:

- 10,000 ft Rated
- Stunning HDTV
- Digital Photos
- LED Lighting
- Rugged and Small
- Highly Maneuverable

### Stunning High Resolution HDTV Imaging

The Sea Maxx is equipped with an advanced undersea HDTV camera optimized for wide angle close-up inspection as well as the ability to zoom in to obtain additional high fidelity detail. Images are recorded, without loss of quality, by a high resolution Digital Video Recorder. Upon completion of ROV operations a customer is able to carry away a full resolution digital HD video and still images on an SD memory card, hard drive or Blu-ray disk.

### Digital Photos

The high quality optics of the HD camera of the Sea Maxx allows operators to obtain visually stunning video and 2.0 mega-pixel digital images. Digital photos can be taken at anytime time during operations with or without ROV sensor data overlay.

### Precision Sensor Suite

The Sea Maxx is equipped with a state of the digital pressure & heading sensor suite allowing for precision operations. It has an "Optional" fiber optics gyro (FOG) that will automatically correct the magnetic flux gate heading sensor while the ROV is operating around steel structures and Installations. All ROV sensor data is overlaid on the Pilot's HDTV monitor and displayed on the CPU monitor video dashboard.

### Cage and TMS

The Sea Maxx is launched and recovered from a protective cage mounted to the Work Class ROV cage which provides AC power, hydraulics and control. The ROV is held securely in the cage by a remote control trapping latch mechanism. The Tether Management System (TMS) is simple, no slip ring, and holds up to 125 meters of 0.5 inch diameter positively buoyant cable.

### Optional

- Scanning Sonar (100 max range)
- Articulated Claw "Hook-Grab-Cut"
- Laser Scaling
- 3D HDTV Camera
- Fiber Optic Gyro - FOG



# SEA MAXX SPECIFICATIONS

## Depth

- 10,000 ft. / 3,050 mtrs.
- 4,000 mtrs. optional

## Size

- Height 18"
- Width 24"
- Length 32" (32" OAL)

## Weight

- In air: 244 lb (104 kg)
- in water: positive 2.5 lb

## Payload:

- 10 lbs. (3.6 kg) in seawater user adjustable w/ lead weights

## Speed:

- Forward: 2.5 knots
- Lateral: 1.0 knots
- Vertical: 1.25 knots

## Thrusters:

- 32 lb of thrust forward
- lateral @ 10 lb of thrust
- vertical @ 14 lb of thrust

## Camera Sensor:

- HDTV Camera Module 1920 x 1080i
- Superwide 3.8x zoom 110° F.O.V. @ full wide
- 0.1 lux light sensitivity
- Optical Glass Dome Port
- HD-SDI FO video link
- Heading Sensor: Micro strain Mini Gyro
- ± 1° resolution Auto heading feedback only
- Optional fiber optics gyro (FOG)

## Depth Sensor:

- ± 1 ft. resolution 10,000 ft

## Tilt:

- Up +45° / down -90°
- Speed 5° to 20° per second
- Controlled via pilots joystick

## Lighting:

- 2 each @ 40 watt LED Lights
- Variable intensity with diffusers

## Flotation:

- High performance syntactic foam
- 27 lb per cubic foot density

## Frame work:

- UHMW and Fiberglass G-10
- With SS hardware and PBOF cabling and junction boxes

## Vehicle Power:

- 1,500 VAC 50/60 hz
- 2.2 kw peak

## Tether Cable:

- Size : 0.50 inch diameter
- Length in TMS 400 ft.
- Breaking strength: 750 lb
- "positively buoyant" .004 lb per foot

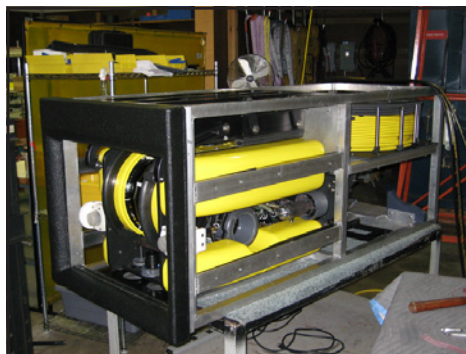
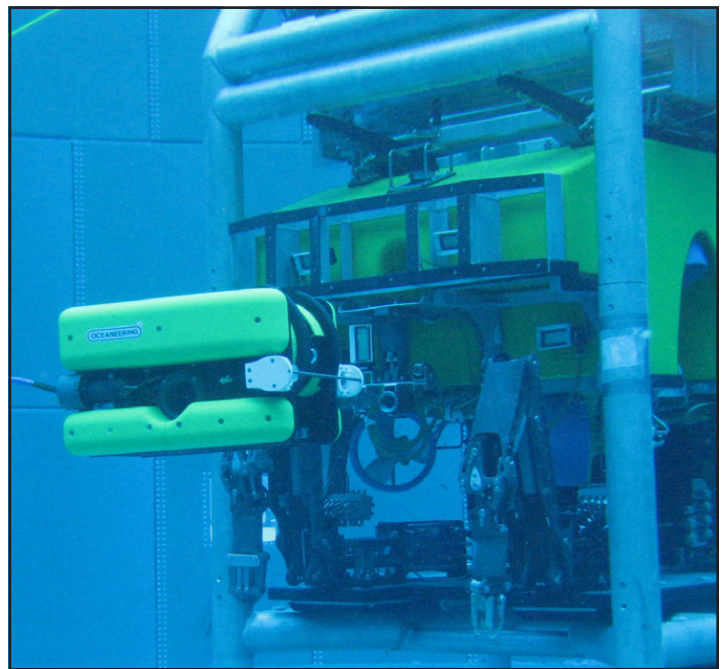

Sea Maxx ROV

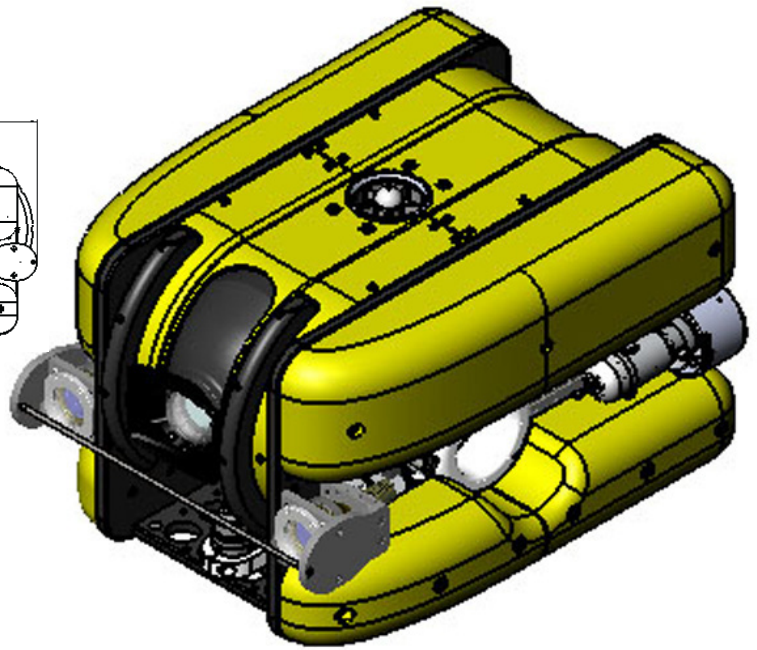
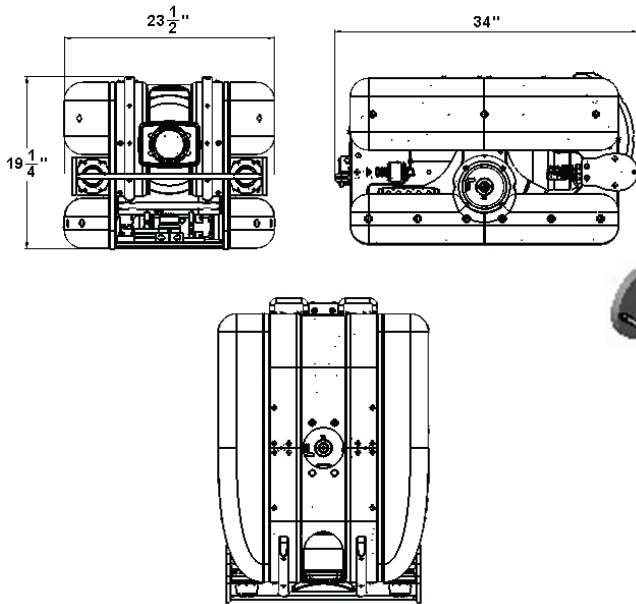

Sea Maxx Cage & TMS

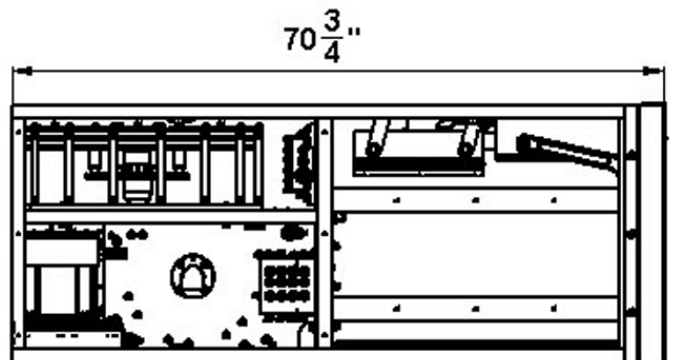
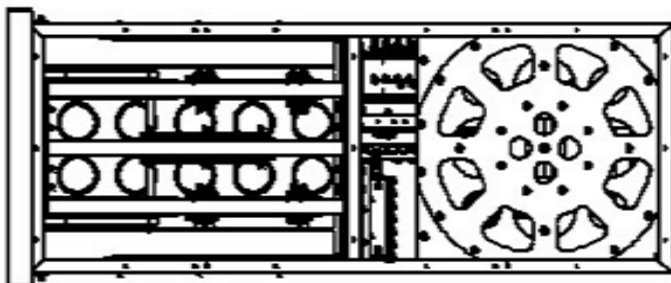
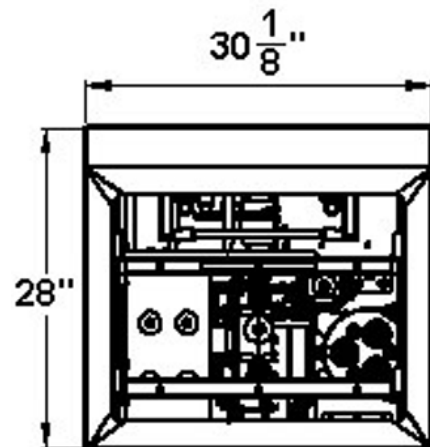
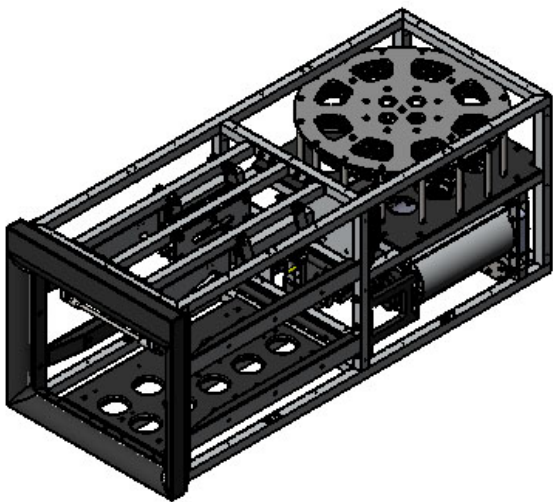



**United States**

San Diego, California  
 Gales Ferry, Connecticut  
 Orlando, Florida  
 Panama City, Florida  
 Pearl Harbor, Hawaii  
 Bayou Vista, Louisiana  
 Houma, Louisiana  
 Lafayette, Louisiana  
 Morgan City, Louisiana  
 New Iberia, Louisiana  
 New Orleans, Louisiana  
 Cataumet, Massachusetts  
 Hanover, Maryland  
 Portsmouth, New Hampshire  
 Austin, Texas  
 Corpus Christi, Texas  
 Clear Lake, Texas  
 Houston, Texas ★  
 Ingleside, Texas  
 Chesapeake, Virginia

**International**

Cabinda, Angola  
 Lobito, Angola  
 Luanda, Angola  
 Perth, W.A., Australia  
 Baku, Azerbaijan  
 Macaé, Brasil  
 Niteroi, Brasil  
 Rio de Janeiro, Brasil  
 St. John's, Newfoundland, Canada  
 Cairo, Egypt  
 Malabo, Equatorial Guinea  
 Tbilisi, Georgia  
 Takoradi, Ghana  
 Mumbai, India  
 Chandigarh, India  
 Kakinada, India  
 Balikpapan, Indonesia  
 Batam, Indonesia  
 Handil, Indonesia  
 Jakarta, Indonesia

Tripoli, Libya  
 Kuala Lumpur, Malaysia  
 Miri, Sarawak, Malaysia  
 Mexico D.F., Mexico  
 Cd. del Carmen, Mexico  
 Ikeja, Lagos, Nigeria  
 Port Harcourt, Nigeria  
 Warri, Nigeria  
 Nodeland, Norway  
 Stavanger, Norway  
 Jurong, Singapore  
 Zug, Switzerland  
 Abu Dhabi, U.A.E.  
 Dubai, U.A.E.  
 Aberdeen, Scotland, U.K.  
 Gloucester, England, U.K.  
 Immingham, England, U.K.  
 London, England, U.K.  
 Mossbank, Shetland Islands, U.K.  
 Port Clarence, North Tees, U.K.

Rosyth, Scotland, U.K.  
 Southampton, England, U.K.  
 Stockton, England, U.K.  
 Swansea, Wales, U.K.  
 Rochester, England, U.K.  
 Whitley Bridge, England, U.K.  
 Wilton, England, U.K.

★ Denotes Corporate Office

